



### 15" Projective Capacitive 10pt touch screen with AG-coating

The ProLite T1532MSC 15" multi-touch screen is based on projected capacitive technology which thanks to a glass overlay covering the screen guarantees high durability, scratch-resistance and perfect picture performance. The anti-glare coating helps to avoid issues with reflections and external light sources affecting colour reproduction, contrast and sharpness. The touch function remains unaffected even if the glass is scratched. A solid and steady base supports the TouchScreen with an adjustable stand offering full 90 degree positioning angles. Menu buttons are located on the side of the screen which can be locked to prevent tampering and includes a handy function to deactivate the TouchScreen for cleaning. In addition the edge-to-edge glass design creates an eye-catching finish with high light transmission guaranteeing perfect picture clarity and brilliant colours.



#### Touch technology - Capacitive

This technology uses a sensor-grid of micro-fine wires integrated into the glass that covers the screen. Touch is detected because electrical characteristics of the sensor grid change when human finger is placed on the glass. Thanks to the glass overlay this technology is highly durable, and the touch function remains unaffected even if the glass is scratched. It offers perfect picture performance and will work with human finger (also latex gloved) and stylus-pen.



#### AG Coating

The anti-glare coating is used in professional-grade displays to help avoid issues with reflections and external light sources affecting colour reproduction, contrast and sharpness. It also makes the screen less susceptible to dust, grease and dirt marks.

## 01 DISPLAY CHARACTERISTICS

Design	Edge to edge glass
Diagonal	15", 38cm
Panel	TN LED, AG coated glass
Native resolution	1024 x 768 (0.8 megapixel)
Aspect ratio	4:3
Brightness	370 cd/m <sup>2</sup> typical
Brightness	315 cd/m <sup>2</sup> with touch
Static contrast	700:1 with touch
Light transmittance	85%
Response time	8ms
Viewing zone	horizontal/vertical: 170°/160°, right/left: 85°/85°, up/down: 80°/80°
Colour support	16.2mIn (6bit + Hi-FRC)
Horizontal Sync	31,4 - 60KHz
Vertical Sync	56 - 75Hz
Viewable area W x H	304.1 x 228.1mm, 12 x 9"
Pixel pitch	0.297mm
Bezel colour and finish	black, matte

## 02 TOUCH

Touch technology	projective capacitive
Touch points	10 (HID, only with supported OS)
Touch method	capacitive stylus, finger, glove
Touch interface	USB
Supported operating systems	All iiyama monitors are Plug & Play and compatible with Windows and Linux. For details regarding the supported OS for the touch models, please refer to the driver instruction file available in the downloads section.

## 03 INTERFACES / CONNECTORS / CONTROLS

Analog signal input	VGA x1
Digital signal input	HDMI x1 DisplayPort x1
Audio output	Speakers 2 x 1W
HDCP	yes

## 04 FEATURES

Water and dust protection	IP54 (front)
OSD key lock	yes

## 05 GENERAL

OSD languages	EN, DE, FR, ES, IT, CN, JP
Control buttons	Menu, Scroll up/ Brightness, Scroll down/ Mute, Select/ Auto, Power
User controls	contrast, brightness, auto adjust, H.position, V.position, H.size, fine, OSD H.position, OSD V.position, OSD timeout, reset, input select, OSD language, colour temperature, volume, mute
Convenience	Kensington-lock™ prepared

Plug&Play

DDC2B

## 06 MECHANICAL

Tilt angle 90° up; 5° down

VESA mounting 100 x 100mm

Cable management system yes

## 07 ACCESSORIES INCLUDED

Cables power, USB, HDMI, Audio, DP

Guides quick start guide, safety guide

Other Touch Panel Driver Disk (CD-ROM)

Cable cover yes

## 08 POWER MANAGEMENT

Power supply unit internal

Power supply AC 100 - 240V, 50/60Hz

Power usage 16W typical, 2W stand by, 2W off mode

## 09 SUSTAINABILITY

Regulations CB, CE, TÜV-Bauart, CU, cULus, VCCI

Energy efficiency class B

Other REACH SVHC above 0.1%: Lead

## 10 DIMENSIONS / WEIGHT

Product dimensions W x H x D 351 x 306.5 x 202mm

Weight (without box) 4.5kg

EAN code 4948570115990

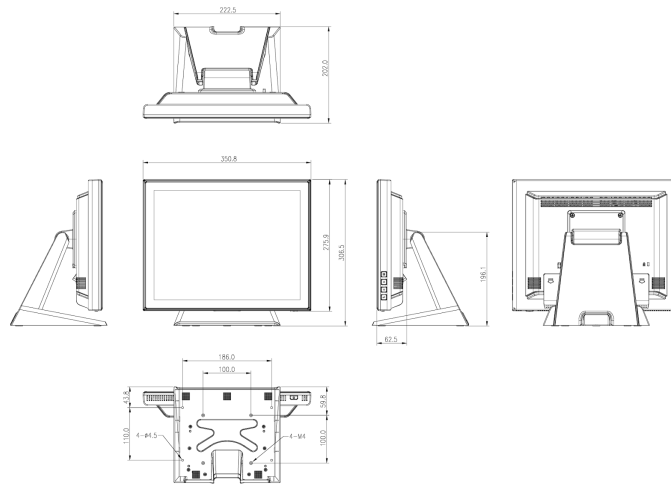

## 11 EU ENERGY EFFICIENCY LABEL

Manufacturer	iiyama
Model	ProLite T1532MSC-B5AG
Energy efficiency class	B
Visible screen diagonal	38cm; 15"; (15" segment)
ON mode power consumption	15.7W
Annual energy consumption	23kWh/annum*
Power in Standby	2W stand by
Resolution	1024 x 768

*This is information under Regulation (EU) No 1062/2010.\*Based on the power consumption of the television operating 4 hours per day for 365 days. The actual energy consumption will depend on how the television is used.*

*All trademarks and registered trademarks acknowledged. E & O E. Specification subject to change without notice. All LCD's comply with ISO-9241-307:2008 in connection with pixel defects.*

© IIYAMA CORPORATION. ALL RIGHTS RESERVED