



22" Dual Touch screen, based on Optical Touch Screen Technology

The T2252MTS is Windows® compatible and ready for the emerging business and consumer software packages. The monitor lets you browse the web, email and draw while working on multiple screens, docking or typing on the on-screen keyboard. You can scroll and rotate pictures, draw, zoom in and out using certain tap, flick, grab and pincer gestures. The multi touch is not only fast but also fun to work with. Multiple inputs (VGA/ HDMI/ DVI) are available for flexible connectivity along with USB for the Touch Interface.



Touch technology - Optical

This technology uses cameras. A touch event is registered with great accuracy when light is blocked by a finger or stylus. It's the only touch technology that does not rely on an overlay or substrate to register a touch, so it's impossible to physically "wear out" the touchscreen. In fact you don't really have to physically touch the screen.



OverDrive ON / OFF

When very fast graphics are displayed your monitor can sometimes get blurry. Turning on the OverDrive feature will eliminate that.

01 DISPLAY CHARACTERISTICS

Diagonal	21.5", 54.7cm
Panel	TN LED-backlit
Native resolution	1920 x 1080 (2.1 megapixel Full HD)
Aspect ratio	16:9
Panel brightness	250 cd/m ²
Brightness	220 cd/m ² with touch
Light transmittance	88%
Static contrast	1000:1
Advanced contrast	12M:1
Response time (GTG)	2ms
Viewing zone	horizontal/vertical: 170°/160°, right/left: 85°/85°, up/down: 80°/80°
Colour support	16.7mln
Horizontal Sync	30 - 80kHz
Viewable area W x H	476.64 x 268.11mm, 18.8 x 10.6"
Pixel pitch	0.248mm
Bezel colour and finish	black, matte

02 TOUCH

Touch technology	optical
Touch points	2 (HID, only with supported OS)
Touch method	stylus, finger, glove
Touch interface	USB
Supported operating systems	All iiyama monitors are Plug & Play and compatible with Windows and Linux. For details regarding the supported OS for the touch models, please refer to the driver instruction file available in the downloads section.

03 INTERFACES / CONNECTORS / CONTROLS

Analog signal input	VGA x1
Digital signal input	DVI x1 HDMI x1
Audio output	Mini jack x1 Speakers 2 x 1W
HDCP	yes

04 FEATURES

OSD key lock	yes
--------------	-----

05 GENERAL

OSD languages	EN, DE, FR, CN, RU, JP, NL, PL
Control buttons	Power, Select/ Input Select, Scroll up/ Audio, Scroll down/ i-Style Colour, Menu
User controls	auto adjust, picture adjust (contrast, brightness, ACR, ECO, OD), input select, audio (volume, mute, HDMI audio), colour adjust (cool, normal, warm, user colour, i-Style colour), information, manual image adjust (H./V. position, clock, phase, sharpness, video mode adjust, blue light reducer), setup menu (language select, OSD position, OSD time out, OSD background, opening logo, LED), memory recall

Convenience	Kensington-lock™ prepared
Blue light reducer	yes
Plug&Play	DDC2B

06 MECHANICAL

Tilt angle	73° up; 3° down
VESA mounting	100 x 100mm

07 ACCESSORIES INCLUDED

Cables	power, VGA, DVI, USB, Audio
Touch pen	x1
Guides	quick start guide, safety guide

08 POWER MANAGEMENT

Power supply unit	internal
Power supply	AC 100 - 240V, 50/60Hz
Power usage	15W typical, 0.5W stand by, 0.5W off mode

09 SUSTAINABILITY

Regulations	CE, TÜV-Bauart, RoHS support, ErP, ENERGY STAR®, WEEE, CU, REACH
REACH SVHC	above 0.1%: Lead

10 DIMENSIONS / WEIGHT

Product dimensions W x H x D	516.5 x 371.5 x 220.5mm
Weight (without box)	5.7kg
EAN code	4948570115174

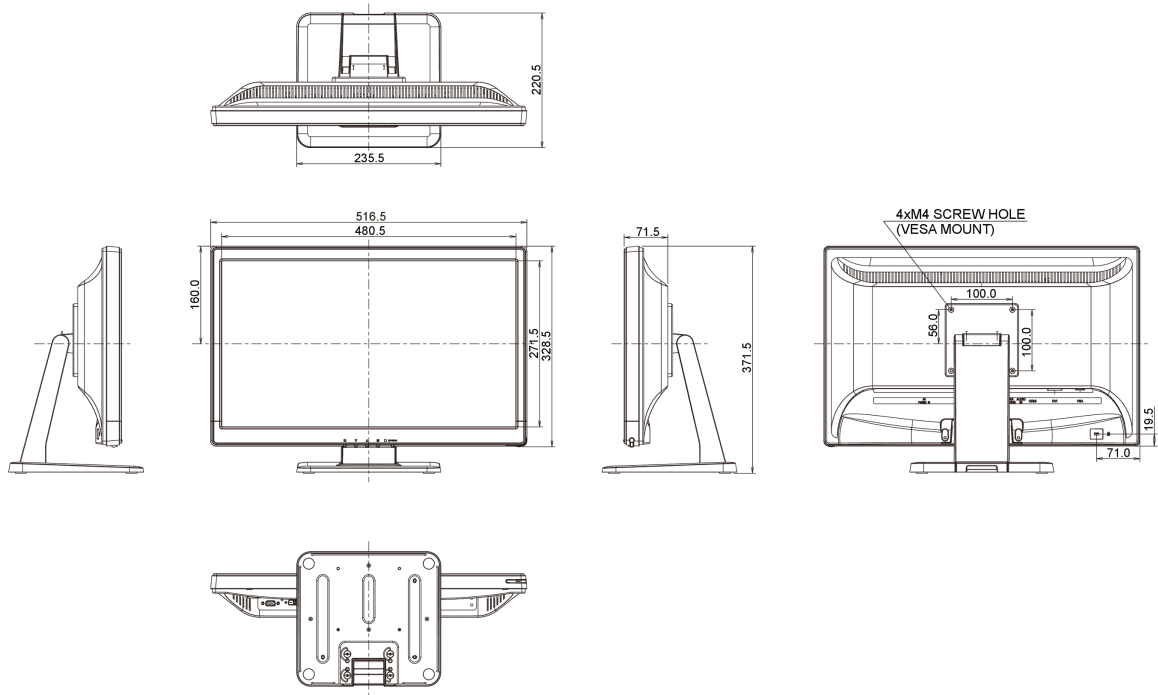

All trademarks and registered trademarks acknowledged. E & O E. Specification subject to change without notice. All LCD's comply with ISO-9241-307:2008 in connection with pixel defects.

© IIYAMA CORPORATION. ALL RIGHTS RESERVED