



ProLite T1532SR is an incredibly powerful touch solution based on the latest 5 Wire Resistive technology. Price / performance ratio is ideal for the budget conscious user while quality and specification is certainly not compromised. The display inputs include both Analogue and Digital (DVI) with Touchscreen connectivity via either USB or RS-232 which offers greater than typical flexibility. A solid and steady base supports the TouchScreen with an adjustable stand offering full 90 degree positioning angles. Extensive Touch Utilities allow for 4 point calibration and 9/25 point linerisation. Menu Buttons are located on the side of the screen which can be locked to prevent tampering, and includes a handy function to deactivate the Touch Screen for cleaning. In addition the bezel free design creates an eye-catching finish with high light transmission guaranteeing perfect picture clarity and brilliant colours.



Tecnología táctil – Resistiva

Las pantallas táctiles resistivas de 5 cables son muy duraderas y se pueden usar en una variedad de entornos. Están especialmente recomendadas para comercios, restaurantes y fines industriales.



IP54

El código IP clasifica la resistencia a los objetos extraños y la humedad. IP54 significa que la pantalla funcionará en condiciones de polvo y resistirá las salpicaduras de agua.

01 CARACTERÍSTICAS DE LA PANTALLA

Diagonal	15", 38cm
Pantalla	TN LED
Resolución nativa	1024 x 768 (0.8 megapixel)
Relación de aspecto	4:3
Brillo	370 cd/m ²
Brillo	300 cd/m ² con touch pantalla
Transmisión de luz	80%
Contraste estático	700:1 con touch pantalla
Tiempo de respuesta (GTG)	8ms
Área de visualización	horizontal/vertical: 170°/160°, derecho/izquierdo: 85°/85°, arriba/abajo: 80°/80°
Soporte de Color	16.7mln
Sincronización horizontal	31.5 - 60.2kHz
Área de visualización h x v	304 x 228mm, 12 x 9"
Pixel pitch	0.297mm
Bisel color y acabado	negro, mate

02 TÁCTILIDAD

Tecnología Touchscreen	resistivo serie
Puntos de contacto	1
Método táctil	pluma, dedo, guante
Touch interface	USB
Sistemas operativos compatibles	All iiyama monitors are Plug & Play and compatible with Windows and Linux. For details regarding the supported OS for the touch models, please refer to the driver instruction file available in the downloads section.

03 INTERFACES / CONECTORES / CONTROLADORES

Conector de entrada analógica	VGA x1
Conector de entrada digital	DVI x1
Salida de audio	Altavoces 2 x 1W

04 CARACTERÍSTICAS

Protección contra el agua y el polvo	IP54 (front)
Bloqueo de teclas OSD	si

05 GENERAL

OSD idioma	EN, DE, FR, ES, IT, CN, JP
Controles	Menu, Scroll up/ Brightness, Scroll down/ Mute, Select/ Auto, Power
Los controles de usuario	contrast, brightness, auto adjust, H.position, V.position, H.size, phase, OSD H.position, OSD V.position, OSD timeout, reset, input select, OSD language, colour temperature, volume, mute
Comodidad	preparado para Kensington-lock™
Plug&Play	DDC2B

06 ASPECTOS MECÁNICOS

Ángulo de inclinación 90° arriba; 5° abajo

Montaje VESA 100 x 100mm

Sistema de gestión de cables si

07 ACCESSORIES INCLUDED

Cable de alimentación, VGA, DVI, USB, Audio

Guía guía de inicio rápido, guía de seguridad

Otro Touch Panel Driver Disk (CD-ROM)

Tapa de cables si

08 GESTIÓN DE ENERGÍA

Unidad de fuente de alimentación interno

Fuente de alimentación AC 100 - 240V, 50/60Hz

Gestión de energía 16W typical, Modo en espera 2W, Modo apagado 2W

09 SOSTENIBILIDAD

Certificados CB, CE, TÜV-Bauart, RoHS support, ErP, WEEE, CU, cULus, VCCI, REACH

REACH SVHC por encima de 0.1% de plomo

10 DIMENSIONES / PESO

Producto dimensiones W x H x D 351 x 306 x 201mm

Peso (sin caja) 4.8kg

Código EAN 4948570114542

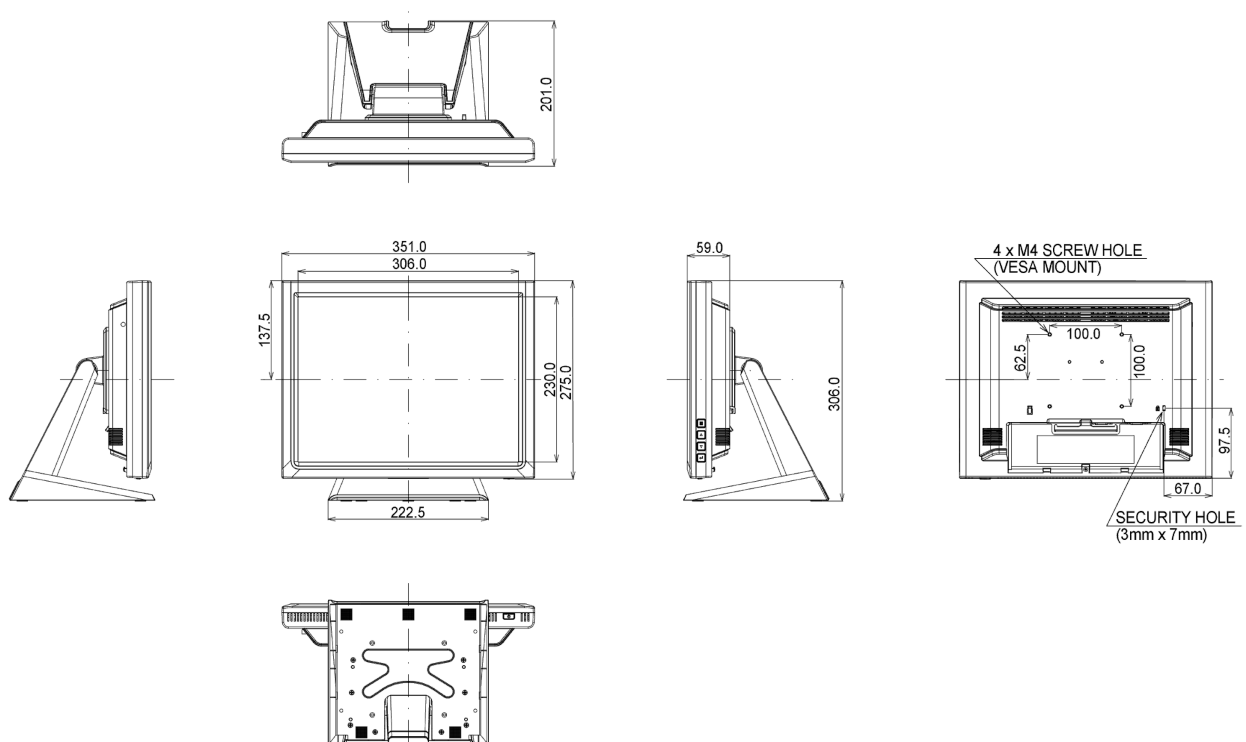

All trademarks and registered trademarks acknowledged. E & O E. Specification subject to change without notice. All LCD's comply with ISO-9241-307:2008 in connection with pixel defects.

© IYAMA CORPORATION. ALL RIGHTS RESERVED