



**27" 10 point multi-touch monitor with Edge to Edge glass and webcam**

With 1920x1080 Full HD resolution and Projective Capacitive 10 point touch technology, the ProLite T2735MSC delivers seamless and accurate touch response. Featuring AMVA+ LED-backlit LCD screen technology, it offers exceptional colour performance and wide viewing angles, making it an excellent choice for a vast array of demanding interactive applications. Users can benefit from its hinged stand allowing the monitor to lay down completely flat for use as a giant tablet. The T2735MSC comes equipped with several video inputs and a USB 3.0 HUB as well as stereo speakers delivering good quality sound. An ideal screen for Interactive Digital Signage, InStore Retail, Gaming and Interactive Presentations purposes.



**Touch technology - Capacitive**

This technology uses a sensor-grid of micro-fine wires integrated into the glass that covers the screen. Touch is detected because electrical characteristics of the sensor grid change when human finger is placed on the glass. Thanks to the glass overlay this technology is highly durable, and the touch function remains unaffected even if the glass is scratched. It offers perfect picture performance and will work with human finger (also latex gloved) and stylus-pen.



**Webcam and microphone**

The built-in webcam and microphone make this monitor a complete solution for online communication. Moreover you can use the touchscreen during a call to easily control your presentation and add annotations.

## 01 DISPLAY CHARACTERISTICS

<b>Design</b>	Edge to edge glass
<b>Diagonal</b>	27", 68.6cm
<b>Panel</b>	AMVA+ LED
<b>Native resolution</b>	1920 x 1080 (2.1 megapixel Full HD)
<b>Aspect ratio</b>	16:9
<b>Panel brightness</b>	300 cd/m <sup>2</sup>
<b>Brightness</b>	255 cd/m <sup>2</sup> with touch
<b>Light transmittance</b>	85%
<b>Static contrast</b>	3 000:1
<b>Advanced contrast</b>	12M:1
<b>Response time (GTG)</b>	5ms
<b>Viewing zone</b>	horizontal/vertical: 178°/178°, right/left: 89°/89°, up/down: 89°/89°
<b>Colour support</b>	16.7mln
<b>Horizontal Sync</b>	24 - 80kHz
<b>Viewable area W x H</b>	597.6 x 336.15mm, 23.5 x 13.2"
<b>Pixel pitch</b>	0.311mm
<b>Bezel colour and finish</b>	black, matte

## 02 TOUCH

<b>Touch technology</b>	projective capacitive
<b>Touch points</b>	10 (HID, only with supported OS)
<b>Touch method</b>	stylus, finger, glove (latex)
<b>Touch interface</b>	USB
<b>Supported operating systems</b>	All iiyama monitors are Plug & Play and compatible with Windows and Linux. For details regarding the supported OS for the touch models, please refer to the driver instruction file available in the downloads section.

## 03 INTERFACES / CONNECTORS / CONTROLS

<b>Analog signal input</b>	VGA x1
<b>Digital signal input</b>	DVI x1 HDMI x1
<b>Audio output</b>	Mini jack x1 Speakers 2 x 2W
<b>USB HUB</b>	x2 (v.3.0)

## 04 FEATURES

<b>Extra</b>	integrated webcam and microphone
<b>OSD key lock</b>	yes

## 05 GENERAL

<b>OSD languages</b>	EN, DE, FR, CN, RU, JP, NL, PL
<b>Control buttons</b>	Power, Select/ Input select, Scroll up/ Audio Adjust, Scroll down/ i-Style Colour, Menu

<b>User controls</b>	auto image adjust, picture adjust (contrast, brightness, ACR, ECO, OD), input select, auto adjust (volume, mute, HDMI audio), color adjust, information, manual image adjust (H./V. position, clock, phase, sharpness, video mode adjust, blue light reducer), setup menu (language select, OSD position, OSD time out, OSD background, opening logo, LED), memory recall
----------------------	---

<b>Convenience</b>	Kensington-lock™ prepared
--------------------	---------------------------

<b>Blue light reducer</b>	yes
---------------------------	-----

<b>Plug&amp;Play</b>	DDC2B
----------------------	-------

## 06 MECHANICAL

<b>Tilt angle</b>	15° up; 70° down
-------------------	------------------

<b>VESA mounting</b>	100 x 100mm
----------------------	-------------

## 07 ACCESSORIES INCLUDED

<b>Cables</b>	power, DVI, USB, Audio
---------------	------------------------

<b>Guides</b>	quick start guide, safety guide
---------------	---------------------------------

## 08 POWER MANAGEMENT

<b>Power supply unit</b>	internal
--------------------------	----------

<b>Power supply</b>	AC 100 - 240V, 50/60Hz
---------------------	------------------------

<b>Power usage</b>	36W typical, 0.5W stand by, 0.5W off mode
--------------------	---

## 09 SUSTAINABILITY

<b>Regulations</b>	CE, TÜV-Bauart, VCCI-B, PSE, RoHS support, ErP, WEEE, CU, REACH
--------------------	---

<b>EPEAT Silver</b>	EPEAT is a comprehensive environmental rating that helps identify greener computers and other electronic equipment. The Silver certification means the monitor meets all required criteria plus at least 50% of the optional requirements. EPEAT Silver is valid in countries where iiyama registers the product. Please visit <a href="http://www.epeat.net">www.epeat.net</a> for the registration status in your country.
---------------------	--

<b>REACH SVHC</b>	above 0.1%: Lead
-------------------	------------------

## 10 DIMENSIONS / WEIGHT

<b>Product dimensions W x H x D</b>	672.5 x 419 x 50mm
-------------------------------------	--------------------

<b>Weight (without box)</b>	8.2kg
-----------------------------	-------

<b>EAN code</b>	4948570114115
-----------------	---------------

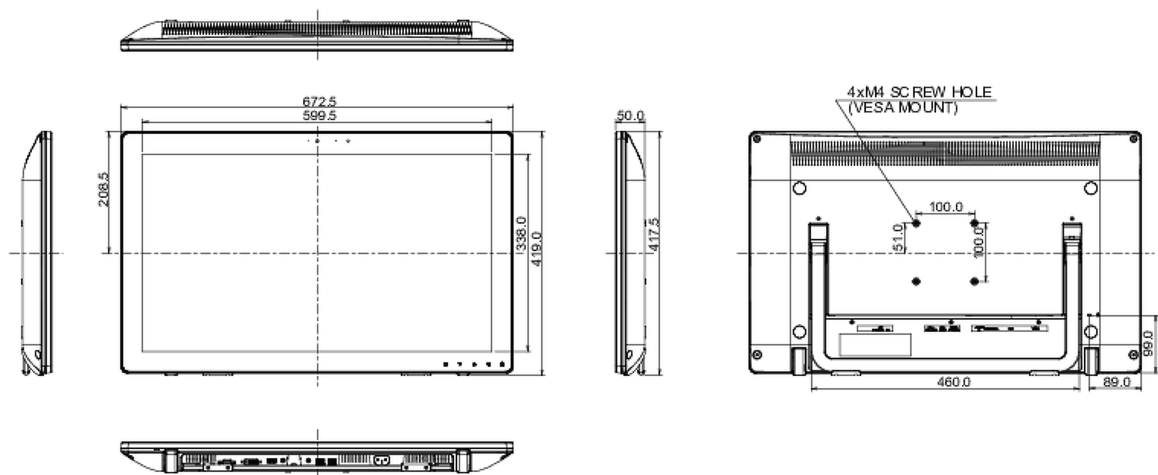

© IYAMA CORPORATION. ALL RIGHTS RESERVED