



The ProLite E2280WSD is a 22" 1680x1050 LED-backlit monitor. It features 5ms black-to-black response

The ProLite E2280WSD is a 22" 1680x1050 LED-backlit monitor. It features 5msec black-to-black response time and 5 000 000 : 1 Advanced Contrast Ratio assuring very good picture quality. Analogue and DVI inputs ensure compatibility with the latest systems and associated graphics cards. The monitor is Energy Star certified. A reliable solution for both home and office use.



LED-backlit

A typical CCFL LCD uses four backlight lamps. Using LED diodes considerably lowers the power consumption and reduces the CO₂ emission into the environment making this LCD a true ECO-Friendly product.

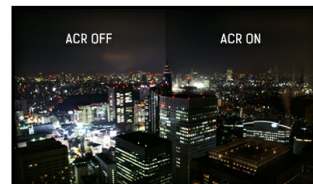

ACR

Contrast Ratio is a measurement of the difference between the darkest black and the brightest white your monitor can display. Advanced Contrast Ratio is a feature that automatically adjusts contrast and brightness of the screen to assure perfect picture quality while watching films and playing games.

01 DISPLAY CHARACTERISTICS

Diagonal	22", 56cm
Panel	TN LED, matte finish
Native resolution	1680 x 1050 (1.8 megapixel)
Aspect ratio	16:10
Panel brightness	250 cd/m ²
Static contrast	1000:1
Advanced contrast	12M:1
Response time (GTG)	5ms
Viewing zone	horizontal/vertical: horizontal°/vertical 178°, right/left: 0°/0°, up/down: 0°/0°
Colour support	16.7mIn (sRGB: 99%; NTSC: 72%)
Horizontal Sync	24 - 83kHz
Viewable area W x H	473.7 x 296.1mm, 18.6 x 11.7"
Pixel pitch	0.282mm
Colour	matte

02 INTERFACES / CONNECTORS / CONTROLS

Signal input	VGA x1 DVI x1
USB HUB	x0
HDCP	yes

03 FEATURES

OSD languages	EN, DE, FR, ES, IT, PT, CN, RU, JP
Control buttons	Power, Menu, +/- Volume, -/ ECO, Auto
User controls	luminance (contrast, brightness, ECO, i-Style Colour, Adv. Contrast), image setup (clock, phase, H. position, V. position, aspect), colour temperature (gamma, colour temperature), OSD setup (H. position, V. position, timeout, language), others (reset, signal select, information)
Speakers	2 x 2W
Convenience	Kensington-lock™ prepared, DDC2B, Mac OSX

04 MECHANICAL

Display position adjustments	tilt
Tilt angle	21° up; 5° down
VESA mounting	100 x 100mm

05 ACCESSORIES INCLUDED

Cables	power, DVI, Audio
Other	quick start guide, safety guide

06 POWER MANAGEMENT

Power supply unit	internal
Power supply	AC AC - 100V, 240V, 50Hz
Power usage	21W typical, 0.5W stand by, 0.5W off mode

07 SUSTAINABILITY

Regulations

CE, TÜV-GS, RoHS support, ErP, ENERGY STAR[®], WEEE, REACH

EPEAT Silver

EPEAT is a comprehensive environmental rating that helps identify greener computers and other electronic equipment. The Silver certification means the monitor meets all required criteria plus at least 50% of the optional requirements. EPEAT Silver is valid in countries where iiyama registers the product. Please visit www.epeat.net for the registration status in your country.

REACH SVHC

above 0.1%: Lead

08 DIMENSIONS / WEIGHT

Product dimensions W x H x D

512.5 x 395.5 x 204.5mm

Weight (without box)

3.6kg

EAN code

4948570111572

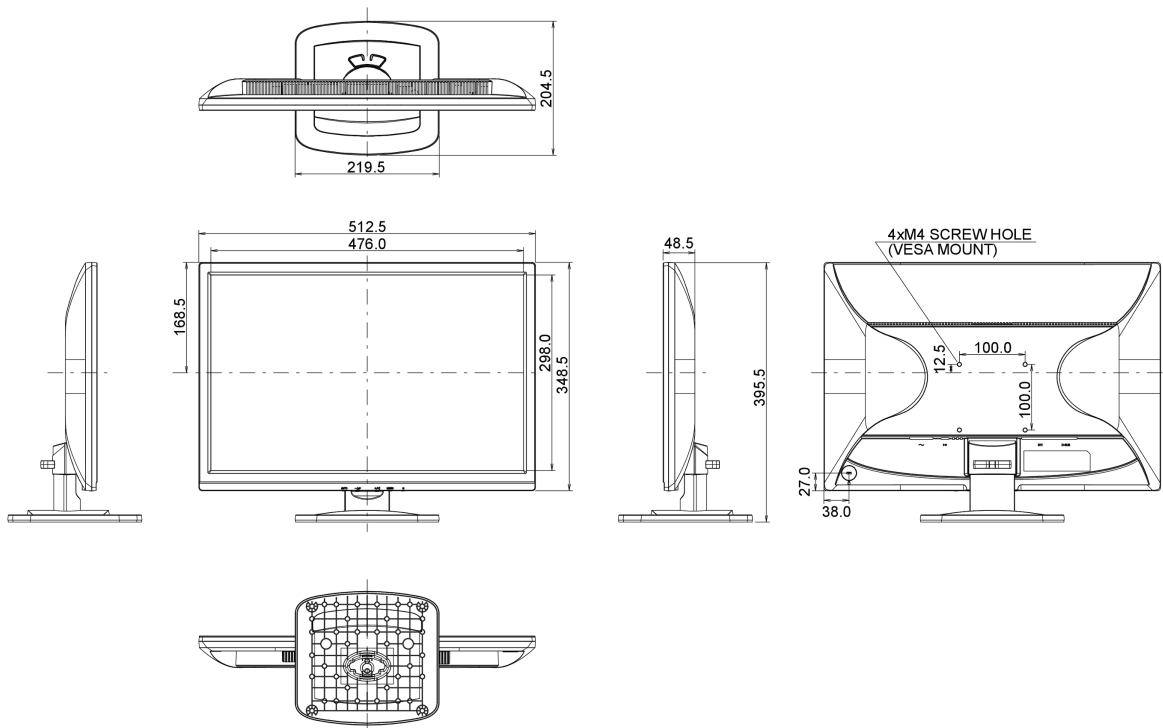

All trademarks and registered trademarks acknowledged. E & O E. Specification subject to change without notice. All LCD's comply with ISO-9241-307:2008 in connection with pixel defects.

© IIYAMA CORPORATION. ALL RIGHTS RESERVED